



NAJJAR

DOORS AND DOOR COMPONENTS



BlockBoard

CATALOGUE

ABOUT US



With over 25 years of experience, NAJJAR Wood Industries is a leading manufacturer of premium blockboards in Egypt. We create durable, high-standard Blockboards that combine strength, reliability, and exceptional value.

Our dedicated team delivers innovative, tailored solutions while prioritizing customer satisfaction at every stage. Committed to sustainability, we integrate responsible sourcing and eco-friendly practices into all our operations. Choose NAJJAR Wood for doors and blockboards that perfectly blend quality, innovation, and sustainability.

Najjar blockboards combine craftsmanship, innovation, and strict adherence to international quality standards to consistently exceed market expectations.

Whether for standard applications or customized projects, Najjar blockboards are designed to provide lasting performance and exceptional value for woodworking professionals worldwide.

WHY NAJJAR ?

- **Exceptional Strength & Stability**

Built for long-lasting durability.

- **Lightweight & Easy to Handle**

Strong yet practical for everyday use.

- **Premium Finishes**

Smooth surface, perfect for laminates, veneers, paint, or decorative applications.

- **Versatile Options**

Available in both finger-jointed and classic styles to meet diverse requirements.

- **Customizable Solutions**

Available in various styles, thicknesses, and finishes to match every project.

- **Eco-Friendly Choice**

Responsibly sourced and environmentally sustainable.

Blockboard

Najjar Blockboard is a precision-engineered wood panel designed for strength, stability, and quality. Available in both finger-jointed and classic styles, it is produced by pressing carefully selected softwood strips between two layers of fine wood veneer. This construction delivers exceptional dimensional stability and reliability, while the solid softwood core ensures superior nail and screw holding capacity, making it more dependable than other engineered boards.

Najjar Blockboard is highly durable, resisting splitting and splintering during cutting. This perfect balance of strength, versatility, and workability makes it the ideal choice for a wide range of applications.



Applications :

- **Doors & Door Frames**
Provides strength and stability while remaining lightweight.
- **Furniture Manufacturing**
Ideal for wardrobes, dressers, tables, and bookshelves.
- **Partitions & Paneling**
Ensures dimensional stability for interior wall cladding and partitions.
- **Worktops & Countertops**
Offers a smooth, durable surface for laminates and veneers.
- **Cabinetry & Kitchen Units**
Resists warping and splitting, perfect for humid environments.
- **Interior Design Solutions**
Suitable for decorative finishes, engravings, and veneered surfaces.
- **Shelving Systems**
Strong yet lightweight, ideal for load-bearing shelves.

Najjar Single Core Blockboards (12-22 mm) 3 PLY & 5 PLY

3 PLY Single Core Blockboards

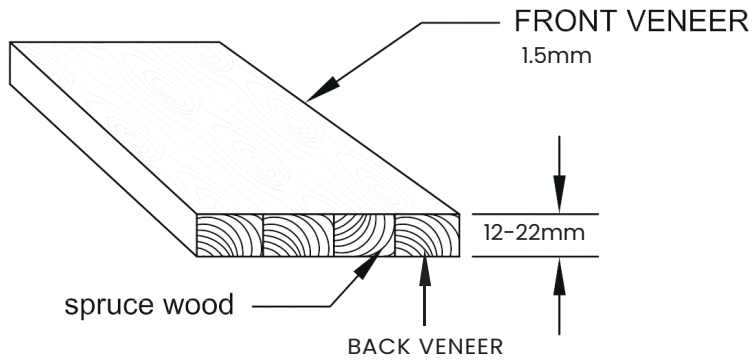

5 PLY Single Core Blockboards

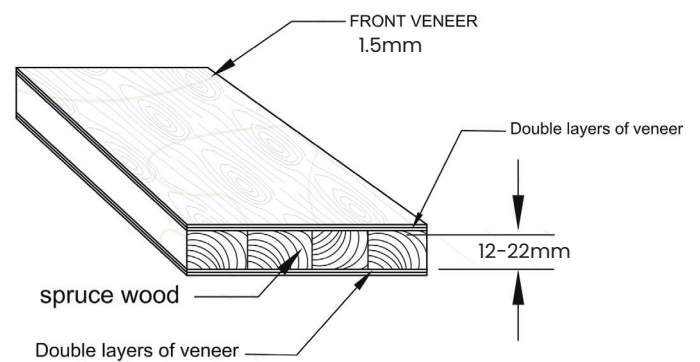

Najjar Single Core Blockboards are crafted with precision using a solid long-grain softwood slat core pressed between high-quality veneer layers. Designed to be lightweight yet durable, they offer excellent dimensional stability, good screw-holding capacity, and a smooth surface ready for laminates, veneers, or paint.



Najjar Double Core Blockboards (30-44 mm)

5 PLY & 7 PLY

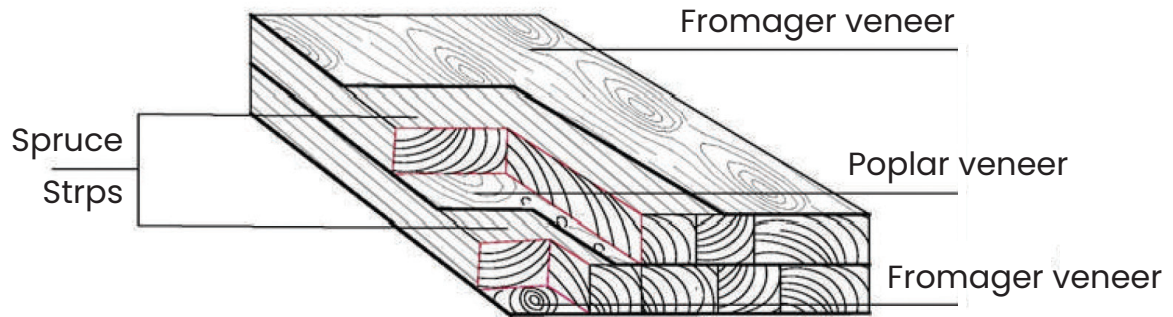

Najjar Double Core Blockboards are crafted with two solid long-grain cores of high-quality softwood slats, pressed between veneer layers to ensure superior strength and stability. Offered in both -5ply and -7ply constructions, they deliver durability, versatility, and a smooth surface finish—ideal for laminates, veneers, or paint. Perfectly engineered for doors, furniture, and interior applications, Najjar Double Core Blockboards provide the balance of performance and design flexibility demanded by modern projects.



BLOCKBOARD TECHNICAL DATA SHEET.



Najjar Blockboards are expertly crafted with a solid wooden slat core, using carefully selected slats that are securely glued together for exceptional rigidity and durability. Both surfaces are reinforced with cross-grain poplar veneer layers, which significantly enhance dimensional stability and effectively prevent warping.

Our outer veneers are fully customizable, available in elegant natural finishes such as oak or beech, as well as high-performance engineered options like melamine, PVC, or HPL to meet any project requirements. With slats meticulously dried to a controlled moisture content of %12–8, our boards deliver unmatched long-term reliability and strength.

Najjar Blockboard – Technical Specifications

Feature	Details
Core (Filler)	Wooden slats, glued for rigidity and durability
Slat Dimensions	Length: 40–80 cm / Width: 15–45 mm
Wood Density	450–550 kg/m ³
Cross Veneer	Cross-grain poplar veneer on both surfaces
Face Veneer	Natural (Oak, Beech, etc.) or Engineered (Melamine,PVC, HPL)
Veneer Thickness	1.2–3.6 mm
Moisture Content	8 % – 12 % (controlled drying for stability)
Thickness Range	12 mm – 44 mm (customizable)

Najjar Single Core Blockboards (12-22 mm) 3 PLY & 5 PLY

Construction :

Core : Solid spruce wooden slats arranged in a single long-grain core, providing reliable rigidity and durability.

Cross Veneers : Each side of the core is reinforced with approximately 1.5 mm cross-grain poplar veneers, ensuring dimensional stability and resistance to warping.

The 5-Ply single core features additional cross-grain veneer layers on each side. This enhances bending resistance, durability, and long-term performance.

Najjar Single Core Blockboards deliver versatility, performance, and reliability across a wide range of interior and furniture applications.

Available sizes :

THICKNESS		12mm	16mm	18mm	22mm
LENGTH X WIDTH	2440x1220mm	✓	✓	✓	✓
LENGTH X WIDTH	2970x1220mm	✓	✓	✓	✓



Najjar Double Core Blockboards (32-44 mm)

5 PLY & 7 PLY

Construction :

Core : Solid spruce wooden slats arranged in two long-grain cores, each 17 mm thick, providing outstanding rigidity and durability.

Cross Veneers : Each side of the core is reinforced with approximately 1.5 mm cross-grain poplar veneers, ensuring dimensional stability and resistance to warping.

Face Veneers : Finished with high-quality natural veneers (Oak, Beech, etc.) or engineered surfaces such as Melamine, PVC, or HPL.

the -7Ply Block board features an additional 1.5 mm longitudinal poplar veneer on each side for greater bending resistance and durability.

Najjar Double block board composition ensures excellent resistance to bending, reliable screw-holding capacity, and a smooth surface for painting, laminating, or veneering.

Available sizes :

THICKNESS		32mm	36mm	44mm
LENGTH X WIDTH	2440x1220mm	✓	✓	✓
LENGTH X WIDTH	2970x1220mm	✓	✓	✓



FINGER JOINT CORE WITHOUT VENEER :

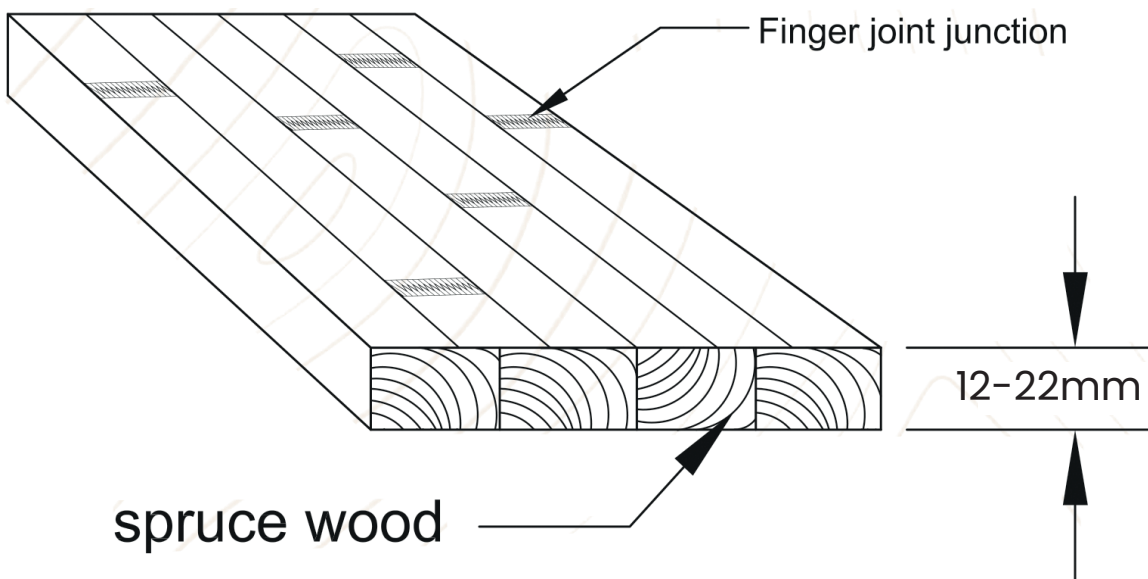



NAJJAR

OUR GLOBAL EXPORTS

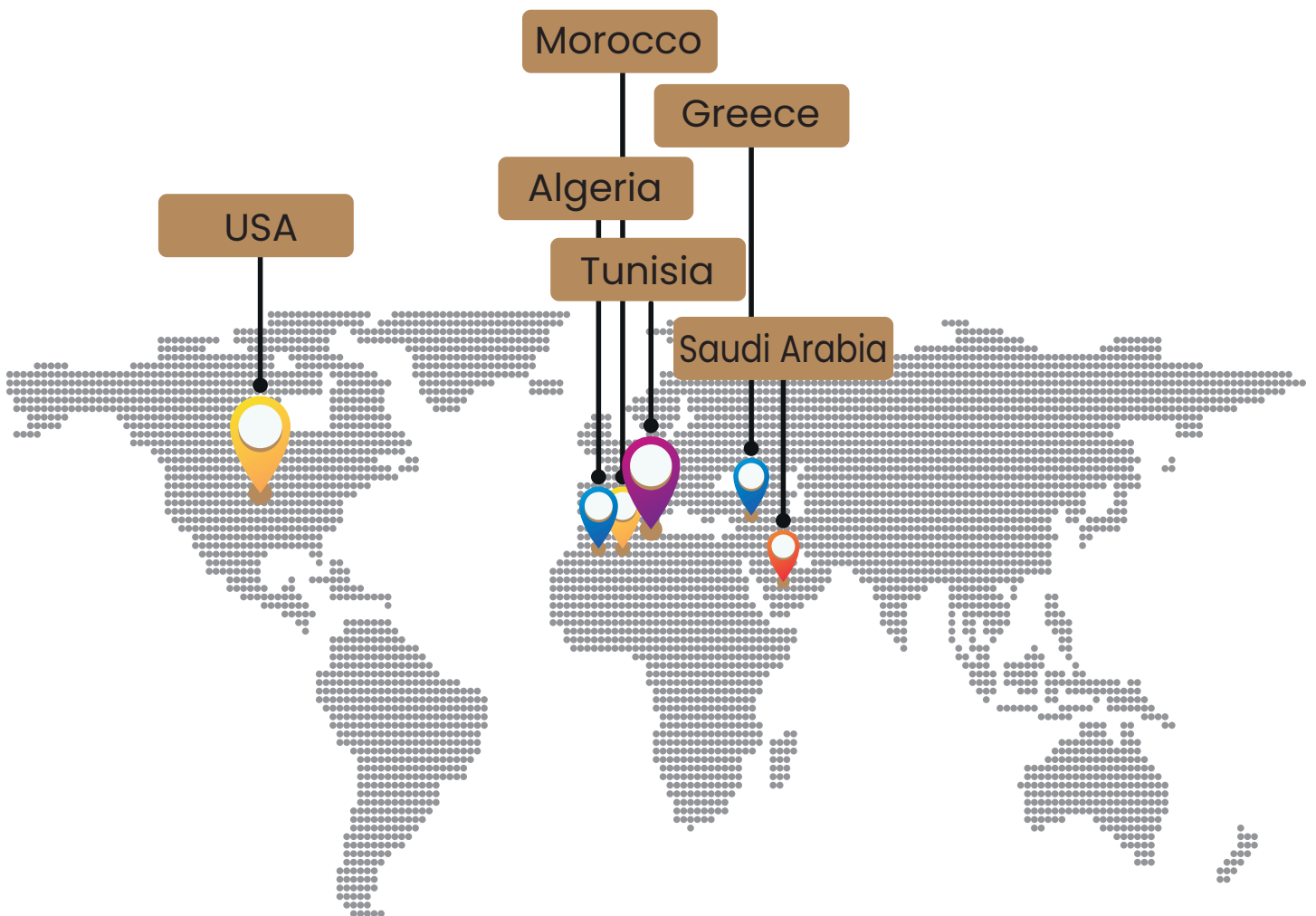

• • N A J J A R



SALES : +2011 012 60 120 / +2010 918 10 002 / +2010 022 04 455

LANDLINE : +202 376 25 110 **FAX** : +202 376 25 115

FACTORIES : Plot No 243 to 247, Wadi Elnatroun, Industrial Zone, Elbehira, Egypt

OFFICE : 6 Ibn Malek st. Giza , Egypt

